

# DOMES

## Series B50/B51/B52/B53

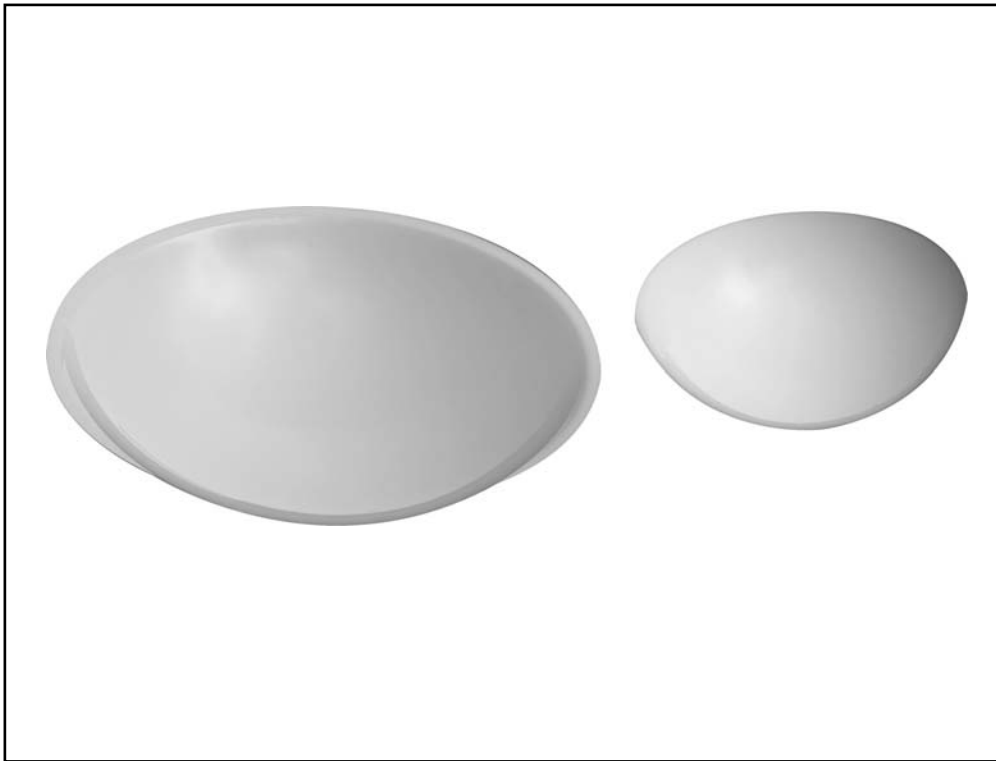

Domes Series

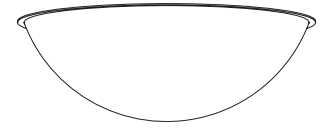

### Series B50/B51/B52/B53

MOLDED LENSES FOR  
COMMERCIAL, RESIDENTIAL  
INSTITUTIONAL,  
INDOOR AND OUTDOOR  
APPLICATIONS

STANDARD MATERIAL:  
FLUORESCENT GRADE  
WHITE ACRYLIC

PLEASE INQUIRE FOR  
FURTHER MATERIAL OPTIONS

### Description

The Series B50/B51/B52/B53 are four basic configurations in free-blown, round domes. Each series is available standard with pattern in finish, pattern out finish available upon request.

The Series B50 is a shallow type of round dome. It is manufactured in white acrylic material with an S81 stipple finish inside of the cavity, smooth finish outside.

The Series B51 is a deeper type of dome with a flange and is available in various sizes and depths ranging from 6" in diameter to 48" in diameter. It is manufactured in white acrylic with an S82 matte finish inside of the cavity, smooth finish outside.

The Series B52 is similar to Series B51, but is designed without a flange. It is manufactured in white acrylic with an S82 matte finish inside of the cavity, smooth finish outside. Mounting holes for the Series B52 can be supplied on request.

The Series B53 is also flangeless but includes a step. It is manufactured in white acrylic with an S82 matte finish inside of the cavity, smooth finish outside.

### Application

The Series B50 domes are designed for fluorescent fixture applications in 2', 3' and 4' diameter modules. The Series B51/B52/B53 are designed for fixtures with a point source where even light distribution is desirable.

### Lamp Data

This product line is designed for various light sources including; fluorescent, incandescent and high-intensity discharge lamps.

### Ordering Information

Please call 800-228-5275 or 231-547-6584 for price and delivery. Specify series and body size when placing an order. Standard product is pattern in, please specify if you want pattern out. Custom sizes, material and thicknesses are available upon request. Typical lead time is four to six weeks.

### Notice

A.L.P. Plastics assumes no responsibility for suitability of luminaires and applications. The use of lenses at excessive temperatures with high UV output light sources will cause degradation of the material.

# Series B50/B51/B52/B53

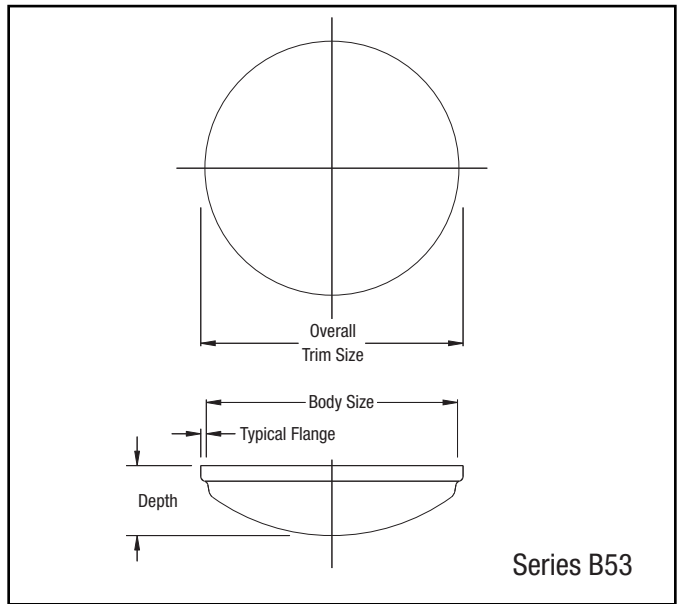
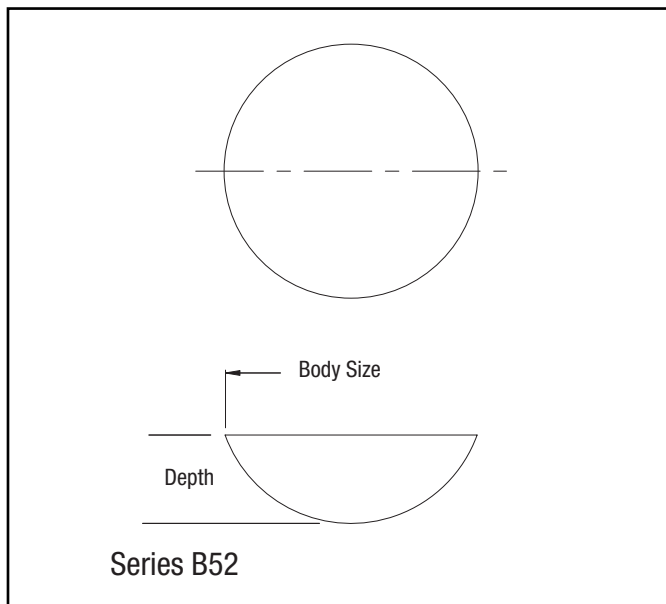
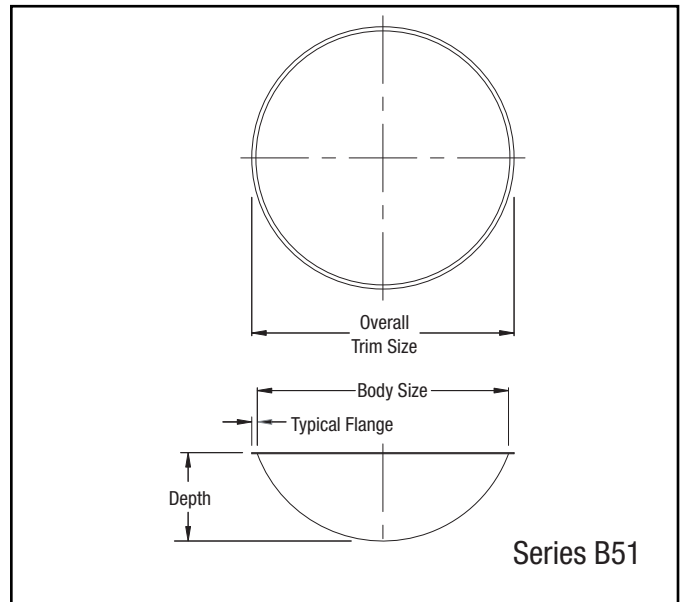
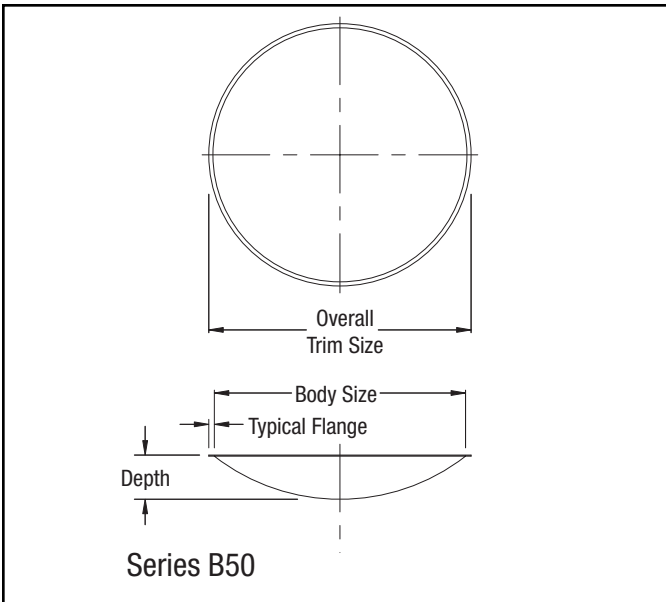

**This drawing is for reference only. Actual part dimensions will vary. Customer is urged to review actual samples to confirm fit and function. All specifications and dimensions are subject to change without notice.**

## Materials

The following materials are used in the production of sheet, profiles, formed and molded parts by A.L.P. Plastics. Please be aware that A.L.P. Plastics does not provide material certifications unless requested by the customer prior to quoting. Our standard manufacturing practice includes the use of reclaimed materials exceeding 25%.

White acrylic: Pigment: Ferco CP51 based material 3-5% max. with any of the following acrylic materials.

### Fluorescent Grade Acrylic:

Altuglas Intl. - UL file #E39437, Materials: V-045, V-825 and V-052. Lucite International - UL file #E65769, Materials: CP-81, MS-983. Cyro Industries - UL file #E54671, Material: H-15. Plaskolite West Inc. - UL file #E167330, Material: CA-81. Please visit our web site for the most current material specifications.

## Series B50/B51/B52/B53

Size	Body Size	Depth
2 ft.	23" Diameter	2" Max
3 ft.	35" Diameter	3" Max
4 ft.	47" Diameter	5" Max